

Bandwidth Management and Traffic Policing in ATM Networks

Mehmet Toygar Karadeniz

Bogazici University

1996

What is ATM ?

- a high-speed service (up to 155 megabits/secs)
- “cells” of information
- insensitive to different types of traffic
- permanent virtual circuits (PVC)
- dynamic bandwidth allocation
- video and voice all over the same network in a cost-effective, easy to manage format

Benefits of ATM

- consolidation
- flexible bandwidth
- simple interconnection
- security
- no obsolescence

LAN vs. ATM Traffic

LAN

- dinner party story
- smaller, interconnected segments of LAN, but more difficult to manage (Ethernet LAN)
- shared-media access methods are probabilistic

ATM

- connection-oriented
- use a deterministic method to allocate resources
- allocates capacity at each connection
- different QoS levels to different traffic types

Types of ATM Traffic

- CBR (constant bit rate)
- VBR (variable bit rate)
- ABR (available bit rate)

Traffic Policing in ATM

- “leaky-bucket” algorithm
- CLP (Cell Loss Priority)
- dual leaky buckets for VBR
- congestion control
 - * end-to-end vs. link-by-link
 - * rate-based vs. credit-based

Network Traffic Types and Their Requirements

Traffic Type	Example	Bandwidth Required	Cell-Delay Variation	Latency
constant	voice	guaranteed	minimal	low
variable	compressed video	guaranteed	variable	low
available	data	not guaranteed	widely variable	variable

What can ATM offer to reduce bandwidth bottlenecks that traditional LAN technologies cannot provide ?

LAN

- primarily support store-and-forward data transfers (connectionless routers)
- no circuit set up for the data exchange.
- sends data on a "best-effort" basis
- sharing pain in congestion

ATM

- connection-oriented (virtual circuits)
- bandwidth will be available when needed
- scalable bandwidth
- better management of traffic without overinvesting bandwidth

CS600 ATM Concentrator

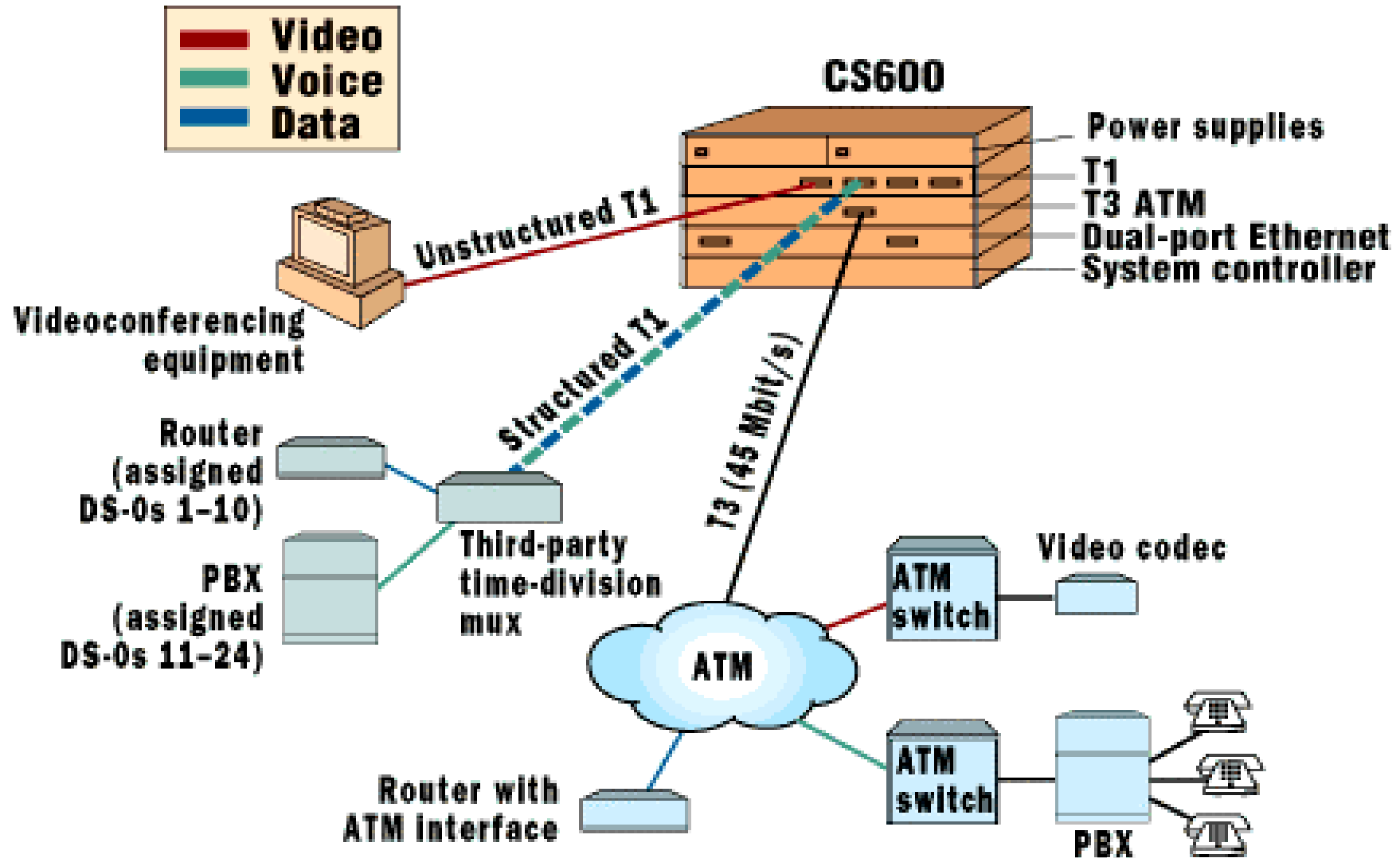

MICOM Marathon®/NetRunner® with MicroBand ATM

■ Bandwidth on Demand

- Dynamically and automatically increasing available bandwidth to accommodate peak traffic loads
- Cost-effectively easing congested conditions
- Saving money on leased line costs by adding traffic capacity for only the absolute minimum period required
- Improving overall corporate-wide network through-put while saving money on network services

■ Bandwidth on Time-of-Day

- Automatically increasing bandwidth for designated time periods to handle recurring traffic requirements
- Allowing sites in multiple time zones to cost-effectively share network resources at different times of day
- Supplementing established links based upon periodic traffic processing demands while minimizing costs
- Limiting access by remote sites to certain times of day, which also limits costs

MICOM Marathon®/NetRunner® with MicroBand ATM (continued)

■ Enhanced Network Resilience

- Enhancing network design to protect mission- critical WAN traffic with Bandwidth Management
- Meeting your individual network requirements with selective WAN link backup for particular sites
- Designating certain times for secondary or backup link activation to avoid excessive network charges
- Cost-effectively utilizing hub-site equipment with M-for-N backup for increased network resiliency

Northern Telecom's Magellan Passport ATM Switch

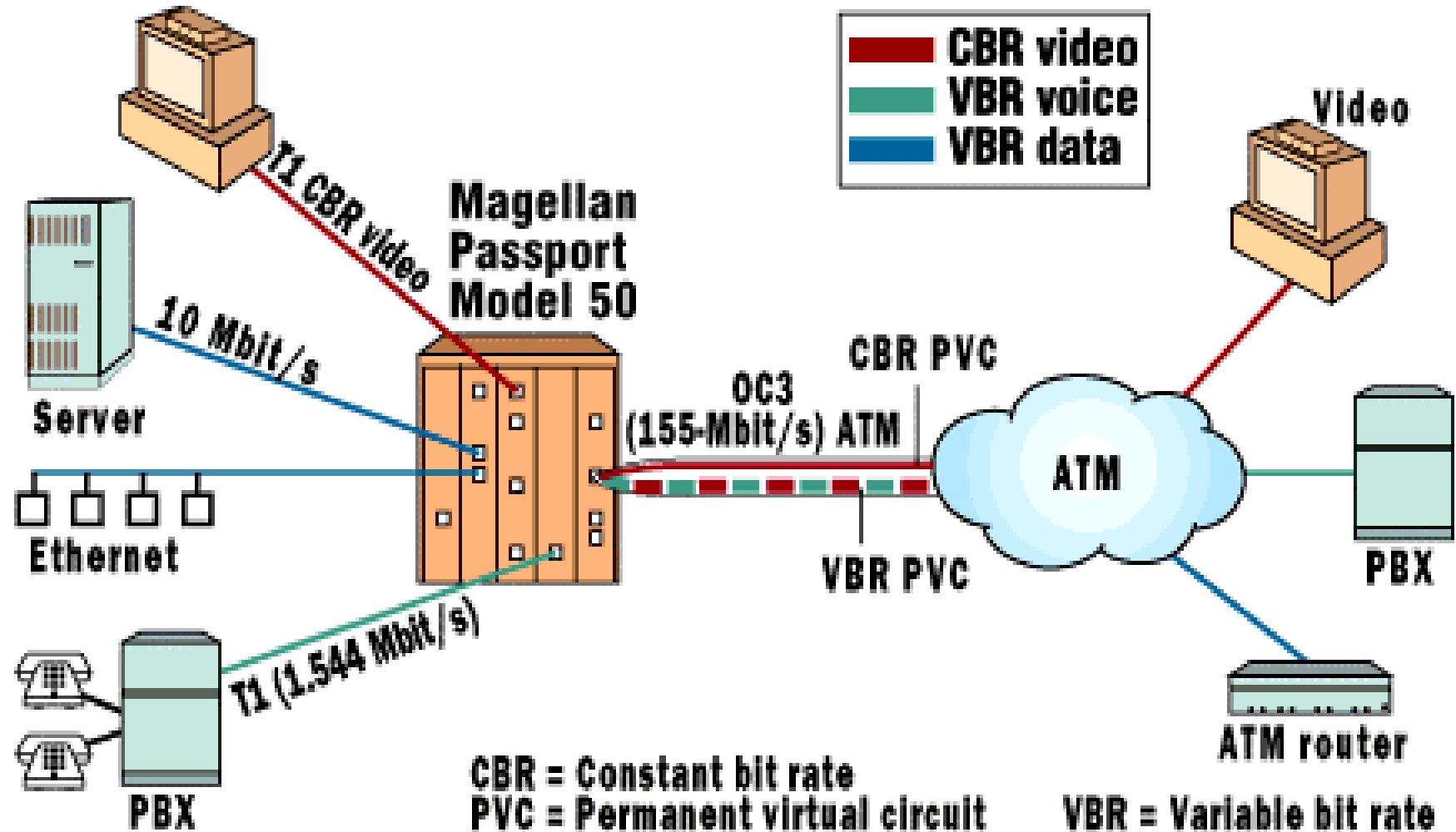

Bandwidth Allocation By Pricing Algorithm In ATM Networks

John Murphy Electronics Engineering Department
Dublin City University
Ireland and Liam Murphy EECS Department
University of California, Berkeley
USA

- Introduction To Algorithm
- Simulation Model
- Results
- Mathematical Formulation

Bandwidth Allocation By Pricing Algorithm

Introduction

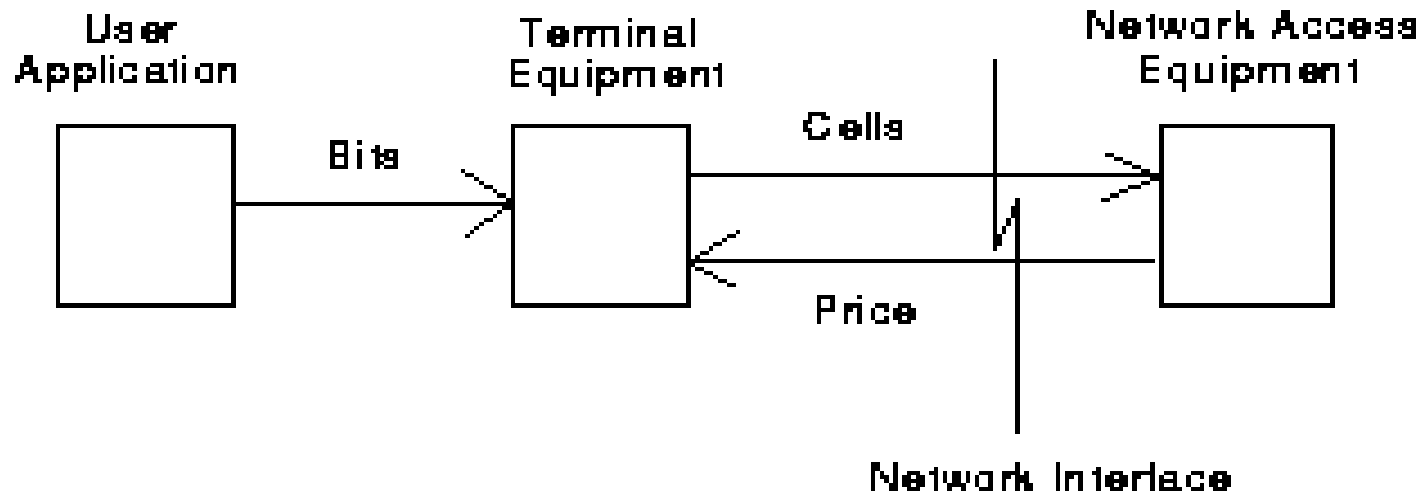

- benefit function
- Virtual Private Network (VPN)
- assigning dynamic priorities

Bandwidth Allocation By Pricing Algorithm Simulation

2023_dissign_2_1		Module: network
Index: Main	Next	Submodule: network_model

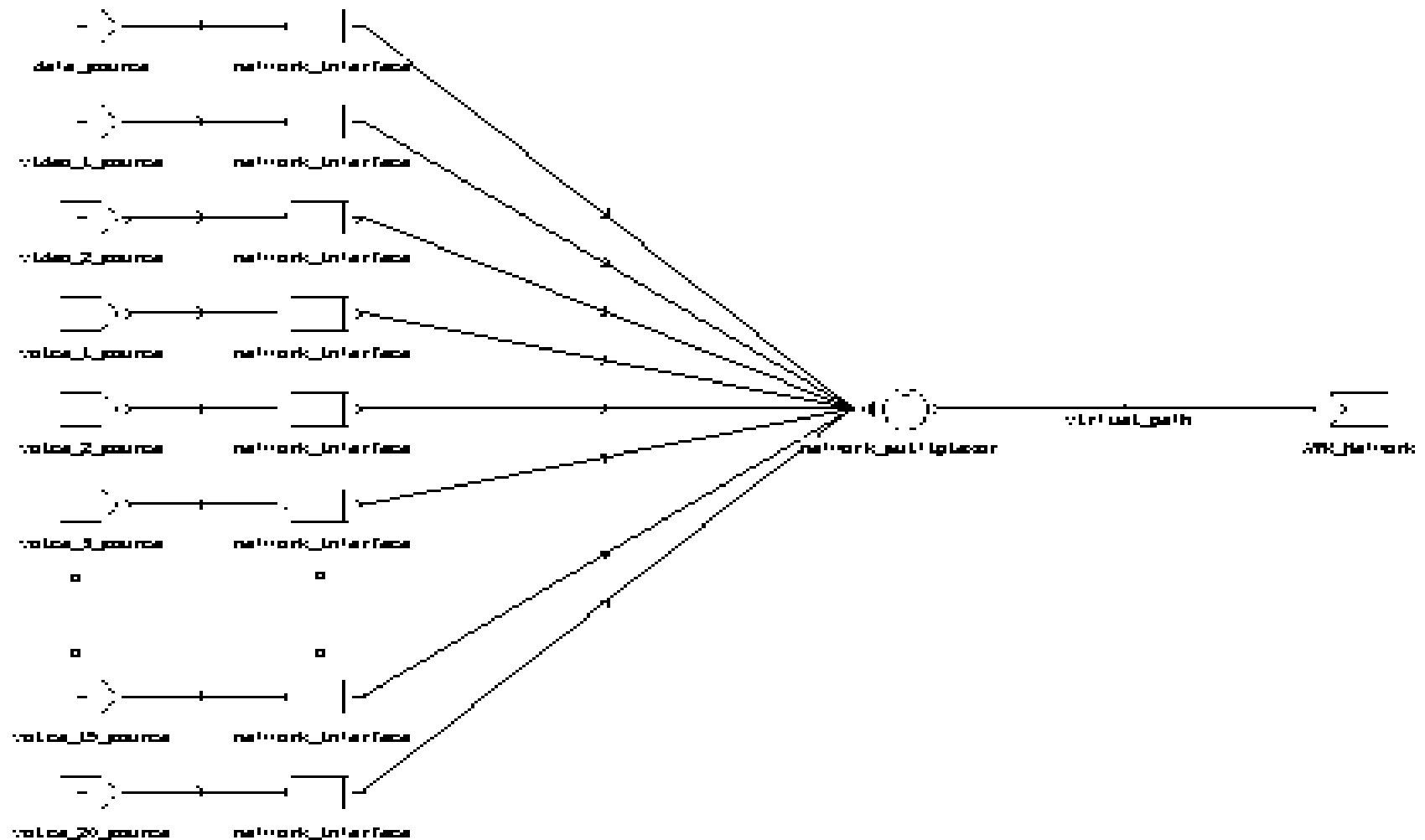

Bandwidth Allocation By Pricing Algorithm Results

Buffer Occupancy with Pricing.

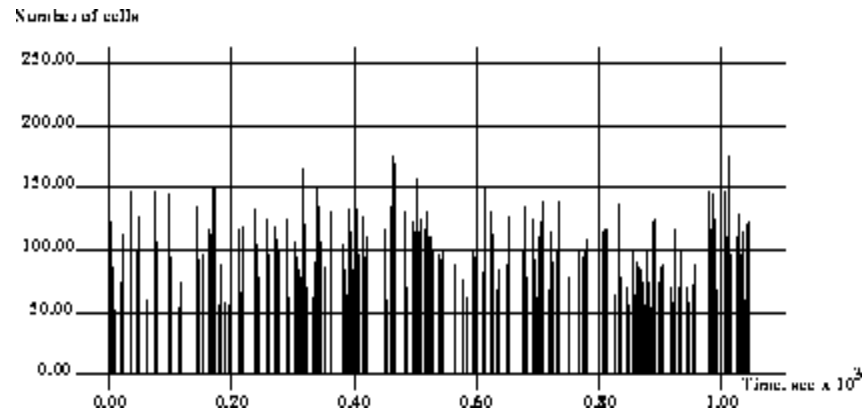

Buffer Occupancy with Leaky Bucket

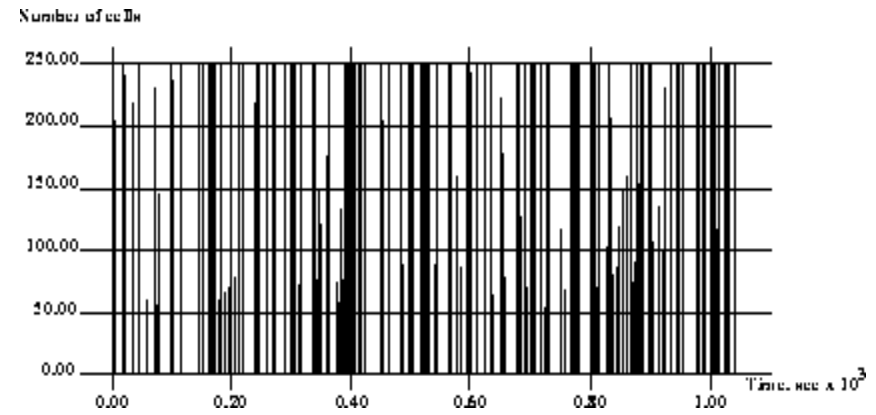

Waiting Times for Data Cells with Pricing

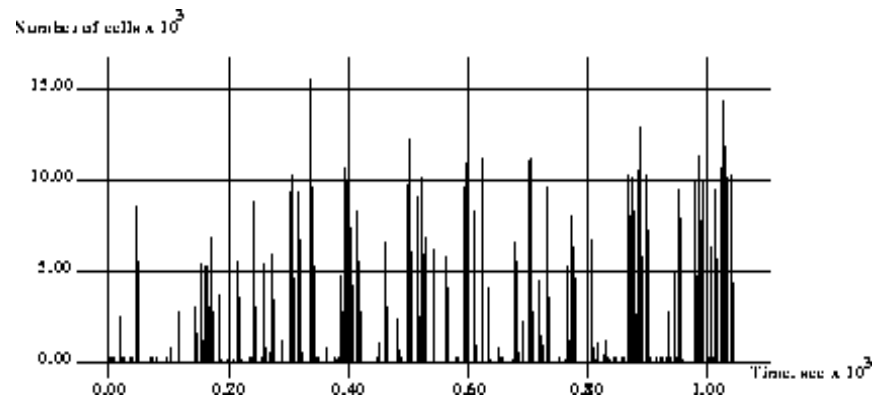

Waiting Times for Data Cells with Leaky Bucket

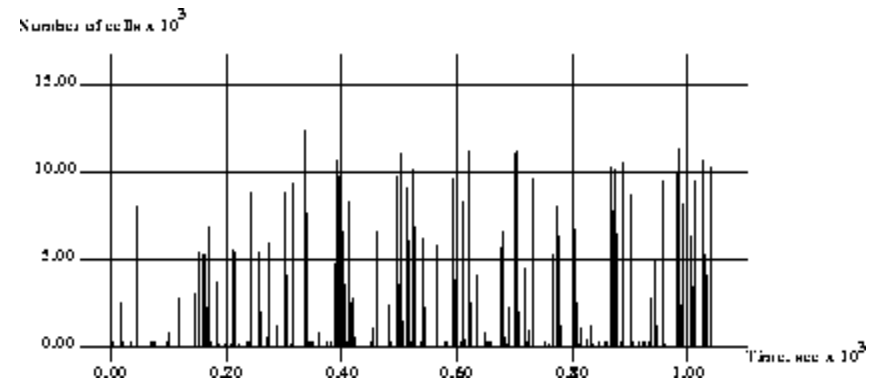

Bandwidth Allocation By Pricing Algorithm

Mathematical Formulation

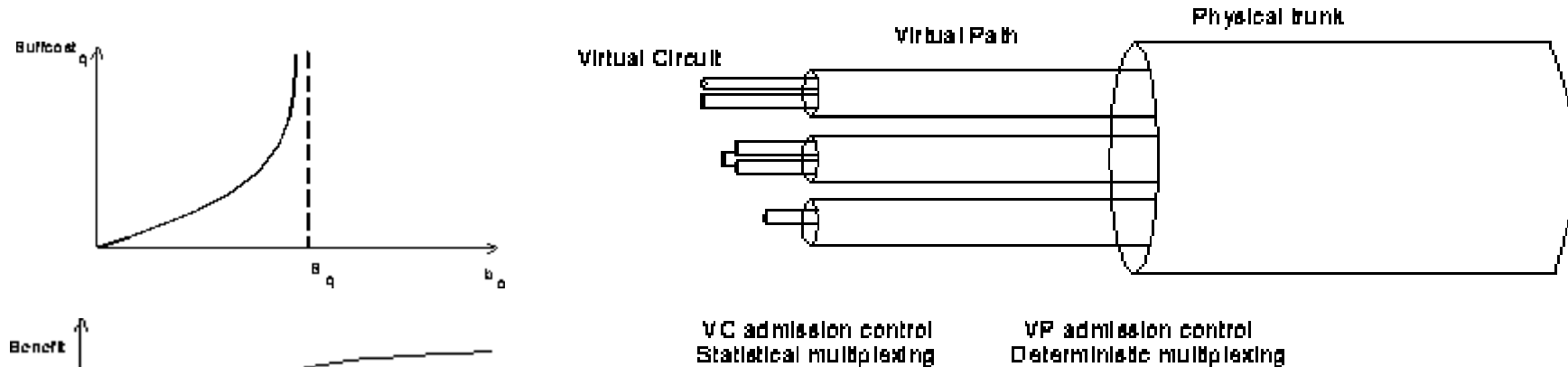

$$\begin{aligned} & \text{maximize } ben_{rq}(b_{rq}) - \pi_q \cdot b_{rq} \\ & b_q \leq B_q, \quad \forall V_q \end{aligned}$$

$$\frac{\partial ben_{rq}}{\partial b_{rq}} - \pi_q = 0, \quad \forall V_q \quad (1)$$

$$\frac{\partial ben_{rq}}{\partial b_{rq}} - \frac{\partial Buffcost_q}{\partial b_q} \cdot \frac{\partial b_q}{\partial (\sum_r b_{rq})} = 0, \quad \forall r, V_q \quad (2)$$

$$\pi_q = \frac{1}{(B_q - b_q)^2} \cdot \frac{\partial b_q}{\partial (\sum_r b_{rq})} \quad (3)$$

$$\text{maximize } \left\{ \sum_{\text{all } V_q} \left[\sum_r ben_{rq}(b_{rq}) \right] - Buffcost_q \right\}$$

$$Buffcost_q := \frac{1}{B_q - b_q} - \frac{1}{B_q}$$

